

REPUBLIC OF KENYA



MANDERA COUNTY GOVERNMENT

**PROPOSED DESILTING AND EXPANSION OF 20,000
CUBIC METRE EARTH PAN AT SUKELA LOQO
MANDERA WEST SUB-COUNTY**

IN

MANDERA COUNTY

TENDER DOCUMENTS

TENDER NO:MCG/OT/2019-2020.....

IFMIS NEGOTIATION NUMBER: 777765

FEB,2020

TABLE OF CONTENTS

	INTRODUCTION
SECTION I	INVITATION FOR TENDERS
SECTION II	INSTRUCTIONS TO TENDERERS
SECTION III	CONDITIONS OF CONTRACT
	APPENDIX TO CONDITIONS OF CONTRACT
SECTION IV	STANDARD FORMS
SECTION V	SPECIFICATIONS, DRAWINGS AND BILLS OF QUANTITIES/SCHEDULE OF RATES...

INTRODUCTION

- 1.1 This standard tender document for procurement of works has been prepared for use by procuring entities in Kenya in the procurement of works (e.g. Buildings, Roads, Bridges, Repairs and Maintenance) which the procuring entity considers to be small and where it is not required to be open tendering.
- 1.2 The following guidelines should be observed when using the document:-
 - (a) Specific details should be furnished in the tender notice and in the special conditions of contract (where applicable). The tender document issued to tenderers should not have blank spaces or options.

 - (b) The instructions to tenderers and the General Conditions of Contract should remain unchanged. Any necessary amendments to these parts should be made through Appendix to instructions to tenderers and special conditions of contract respectively.
- 1.3 (a) Information contained in the invitation to tender shall conform to the data and information in the tender documents to enable prospective tenderers to decide whether or not to participate in the tender and shall indicate any important tender requirements
 - I. The invitation to tender shall be as an advertisement in accordance with the regulations or a letter of invitation addressed to tenderers who have been prequalified following a request for prequalification.
- 1.4 The cover of the tender document should be modified to include:-
 - II. Tender number.
 - III. Tender name.
 - IV. Name of procuring entity.
 - V. Delete name and address of PPOA.

SECTION I

INVITATION FOR TENDERS

Tender reference no. : MCG/OT/2019-2020

Tender Name: PROPOSED DESILTING AND EXPANSION OF 20,000 CUBIC METRE EARTH PAN AT SUKELA LOQO MANDERA WEST SUB-COUNTY.

1.1 The Mandera *County Government* invites sealed PROPOSED DESILTING AND EXPANSION OF 20,000 CUBIC METRE EARTH PAN AT SUKELA LOQO MANDERA WEST SUB-COUNTY. candidates may obtain further information from the office of the director supply chain management services at the county treasury during normal working hours and via email on supplychain@mandera.go.ke.

1.2 Invitation to tender containing detailed information, tenders number and negotiation numbers and the tender documents can be downloaded free of charge at the county's website www.mandera.go.ke. and also at the tenders portal at tenders.go.ke which can also be accessed from supplier's portal

1.3 Completed set of tender documents shall be scanned and submitted electronically through IFMIS SUPPLIER PORTAL at supplier.treasury.go.ke using the specific IFMIS negotiation number provided in the tender documents as per the requirements contained in the tender documents so as to be received on or before **Thursday 5th March 2020**.

1.4 Bidders must upload a copy of original bid security to the ifmis portal and deliver ORIGINAL bid security to the office of the director supply chain management.

NOTE: The system will automatically close at the time and date of tender closing specified on the IFMIS portal and tender documents. The system does not have provisions for late submission.

MANUAL SUBMISSIONS WILL NOT BE ACCEPTED, all tenders must be submitted through IFMIS PORTAL

All bidders are advised to regularly check the county's website during the bidding period,

Director of Supply Chain Management services
FOR: COUNTY CHIEF OFFICER ACCOUNTING AND FINANCIAL SERVICES

SECTION II
INSTRUCTIONS TO TENDERERS

TABLE OF CONTENTS

CLAUSE	
1 .	GENERAL -----
2.	TENDER DOCUMENTS -----
3.	PREPARATION OF TENDERS -----
4.	SUBMISSION OF TENDERS -----
5.	TENDER OPENING AND EVALUATON -----
6.	AWARD OF CONTRACT -----

INSTRUCTIONS TO TENDERERS.

1. General

- 1.1 The Employer as defined in the Appendix to Conditions of Contract invites tenders for Works Contract as described in the tender documents. The successful Tenderer will be expected to complete the Works by the Intended Completion Date specified in the said Appendix.
- 1.2 Tenderers shall include the following information and documents with their tenders, unless otherwise stated:
 - (a) copies of certificates of registration, and principal place of business;
 - (b) total monetary value of construction work performed for each of the last five years;
 - (c) experience in works of a similar nature and size for each of the last five years, and clients who may be contacted for further information on these contracts;
 - (d) major items of construction equipment owned;
 - (e) qualifications and experience of key site management and technical personnel proposed for the Contract;
 - (f) reports on the financial standing of the Tenderer, such as profit and loss statements and auditor's reports for the last five years;
 - (g) authority to seek references from the Tenderer's bankers.
- 1.3 The Tenderer shall bear all costs associated with the preparation and submission of his tender, and the Employer will in no case be responsible or liable for those costs.
- 1.4 The Tenderer, at the Tenderer's own responsibility and risk, is encouraged to visit and examine the Site of the Works and its surroundings, and obtain all information that may be necessary for preparing the tender and entering into a contract for construction of the Works. The costs of visiting the Site shall be at the Tenderer's own expense.
- 1.5 The procurement entity's employees, committee members, board members and their relative (spouse and children) are not eligible to participate in the tender.
- 1.6 The price to be charged for the tender document shall not exceed Kshs.1,000/=

1.7 The procuring entity shall allow the tenderer to review the tender document free of charge before purchase.

2. Tender Documents

2.1 The complete set of tender documents comprises the documents listed here below and any addenda issued in accordance with clause

2.4 Here below:-

- (a) These instructions to Tenderers
- (b) Form of Tender
- (c) Conditions of Contract and Appendix to Conditions of Contract
- (d) Specifications
- (e) Drawings
- (f) Bills of Quantities/Schedule of Rates (whichever is applicable)
- (g) Other materials required to be filled and submitted in accordance with these Instructions and Conditions

2.2 The Tenderer shall examine all instructions, forms and tender specifications in the documents. Failure to furnish all by the information required tender documents may result in rejection of his tender.

2.3 A prospective Tenderer making inquiries of the tendering documents may notify the Employer in writing or by cable, telex or facsimile at the address indicated in the letter of invitation to tender. The Employer will respond to any request for clarification received earlier than seven [7] days prior to the deadline for submission of tenders. Copies of the Employer's response will be forwarded to all persons issued with tendering documents, including a description of the inquiry, but without identifying its source.

2.4 Before the deadline for submission of tenders, the Employer may modify the tendering documents by issuing addenda. Any addendum thus issued shall be part of the tendering documents and shall be communicated in writing or by cable, telex or facsimile to all Tenderers. Prospective Tenderers shall acknowledge receipt of each addendum in writing to the Employer.

2.5 To give prospective Tenderers reasonable time in which to take an addendum into account in preparing their tenders, the Employer shall extend, as necessary, the deadline for submission of tenders in accordance with clause 4.2 here below.

3 Preparation of Tenders

3.1 All documents relating to the tender and any correspondence shall be in English Language.

3.2 The tender submitted by the Tenderer shall comprise the following:-

- (a) The Tender;
- (b) Tender Security;
- (c) Priced Bill of Quantities/Schedule of Rates for lump-sum Contracts
- (d) Any other materials required to be completed and submitted by Tenderers.

3.3 The Tenderer shall fill in rates and prices for all items of the Works described in the Bill of Quantities/Schedule of Rates. Items for which no rate or price is entered by the Tenderer will not be paid for when executed and shall be deemed covered by the other rates and prices in the Bill of Quantities/Schedule of Rates. All duties, taxes and other levies payable by the Contractor under the Contract, as of 30 days prior to the deadline for submission of tenders, shall be included in the tender price submitted by the Tenderer.

3.4 The rates and prices quoted by the Tenderer shall not be subject to any adjustment during the performance of the Contract.

3.5 The unit rates and prices shall be in Kenya Shillings.

3.6 Tenders shall remain valid for a period of sixty (60) days from the date of submission. However in exceptional circumstances, the Employer may request that the Tenderers extend the period of validity for a specified additional period. The request and the Tenderers' responses shall be made in writing.

3.7 The Tenderer shall prepare one original and a copy of the

documents comprising the tender documents as described in these Instructions to Tenderers.

- 3.8 The original shall be typed or written in indelible ink and shall be signed by a person or persons duly authorized to sign on behalf of the Tenderer. All pages of the tender where alterations or additions have been made shall be initialed by the person or persons signing the tender.
- 3.9 Clarification of tenders shall be requested by the tenderer to be received by the procuring entity not later than 7 days prior to the deadline for submission of tenders.
- 3.10 The procuring entity shall reply to any clarifications sought by the tenderer within 3 days of receiving the request to enable the tenderer to make timely submission of its tender.

4 Submission of Tenders

4.1 The tender duly filled and sealed in an envelope shall;-

- (a) be addressed to the Employer at the address provided in the invitation to tender;
- [b] bear the name and identification number of the Contract as defined in the invitation to tender; and
- [c] provide a warning not to open before the specified time and date for tender opening.

4.2 Tenders shall be delivered to the Employer at the address specified above not later than the time and date specified in the invitation to tender.

4.3 The tenderer shall not submit any alternative offers unless they are specifically required in the tender documents.

Only one tender may be submitted by each tenderer. Any tenderer who fails to comply with this requirement will be disqualified.

4.4 Any tender received after the deadline for opening tenders will be returned to the tenderer un-opened.

4.5 The Employer may extend the deadline for submission of tenders by issuing an amendment in accordance with sub-clause 2.5 in

which case all rights and obligations of the Employer and the Tenderers previously subject to the original deadline will then be subject to the new deadline.

5. Tender Opening and Evaluation

5.1 The tenders will be opened in the presence of the Tenderers' representatives who choose to attend at the time and in the place specified in the invitation to tender.

5.2 The Tenderers' names, the total amount of each tender and such other details as may be considered appropriate, will be announced at the opening by the Employer . Minutes of the tender opening, including the information disclosed to those present will also be prepared by the Employer.

5.3 Information relating to the examination, clarification, evaluation and comparison of tenders and recommendations for the award of the Contract shall not be disclosed to Tenderers or any other persons not officially concerned with such process until the award to the successful Tenderer has been announced. Any effort by a Tenderer to influence the Employer's officials, processing of tenders or award decisions may result in the rejection of his tender.

5.4 Tenders determined to be substantially responsive will be checked for any arithmetic errors. Errors will be corrected as follows:

- (a) where there is a discrepancy between the amount in figures and the amount in words, the amount in words will prevail; and
- (b) where there is a discrepancy between the unit rate and the line item total resulting from multiplying the unit rate by the quantity, the unit rate as quoted will prevail, unless in the opinion of the Employer's representative, there is an obvious typographical error, in which case the adjustment will be made to the entry containing that error.
- (c) In the event of a discrepancy between the tender amount as stated in the Form of Tender and the corrected tender figure in the main summary of the Bill of Quantities/Quotation, the amount as stated in the Form of Tender shall prevail.
- (d) The Error Correction Factor shall be computed by expressing the difference between the tender amount and the corrected

tender sum as a percentage of the Corrected Builder's Work (i.e. corrected tender sum less P.C. and Provisional Sums).

- (e) The Error Correction Factor shall be applied to all Builder's Work (as a rebate or addition as the case may be) for the purposes of valuations for Interim Certificates and valuation of variations.
 - (f) The amount stated in the tender will be adjusted in accordance with the above procedure for the correction of errors and with concurrence of the Tenderer, shall be considered as binding upon the Tenderer. If the Tenderer does not accept the corrected amount, the tender may be rejected and the Tender Security forfeited.
- 5.5 The tender evaluation committee shall evaluate the tender within 30 days of the validity period from the date of opening the tender.
- 5.6 Contract price variations shall not be allowed for contracts not exceeding one year (12 months)
- 5.7 Where contract price variation is allowed, the valuation shall not exceed 15% of the original contract price.
- 5.8 Price variation requests shall be processed by the procuring entity within 30 days of receiving the request. Preference where allowed in the evaluation of tenders shall not exceed 15%
- 5.9 To assist in the examination, evaluation, and comparison of tenders, the Employer at his discretion, may request [in writing] any Tenderer for clarification of the tender, including breakdowns of unit rates. The request for clarification and the response shall be in writing or by cable, telex or facsimile but no change in the tender price or substance of the tender shall be sought, offered or permitted.
- 5.10 The Tenderer shall not influence the Employer on any matter relating to his tender from the time of the tender opening to the time the Contract is awarded. Any effort by the Tenderer to influence the Employer or his employees in his decision on tender evaluation, tender comparison or Contract award may result in the rejection of the tender.

6. Award of Contract

- 6.1 The award of the Contract will be made to the Tenderer who has offered the lowest evaluated tender price.
- 6.2 Notwithstanding the provisions of clause 6.1 above, the Employer reserves the right to accept or reject any tender and to cancel the tendering process and reject all tenders at any time prior to the award of Contract without thereby incurring any liability to the affected Tenderer or Tenderers or any obligation to inform the affected Tenderer or Tenderers of the grounds for the action.
- 6.3 The Tenderer whose tender has been accepted will be notified of the award prior to expiration of the tender validity period in writing or by cable, telex or facsimile. This notification (hereinafter and in all Contract documents called the "Letter of Acceptance") will state the sum [hereinafter and in all Contract documents called the "Contract Price" which the Employer will pay the Contractor in consideration of the execution, completion, and maintenance of the Works by the Contractor as prescribed by the Contract. The contract shall be formed on the parties signing the contract. At the same time the other tenderers shall be informed that their tenders have not been successful.
- 6.4 The Contract Agreement will incorporate all agreements between the Employer and the successful Tenderer. It will be signed by the Employer and sent to the successful Tenderer, within 30 days following the notification of award. Within 21 days of receipt ,the successful Tenderer will sign the Agreement and return it to the Employer.
- 6.5 Within 21 days after receipt of the Letter of Acceptance, the successful Tenderer shall deliver to the Employer a Performance Security amount stipulated in the Appendix to Conditions of Contract.
- 6.6 The parties to the contract shall have it signed within 30 days from the date of notification of contract award unless there is an administrative review request.
- 6.7 The procuring entity may at any time terminate procurement proceedings before contract award and shall not be liable to any person for the termination.

6.8 The procuring entity shall give prompt notice of the termination to the tenderers and on request give its reasons for termination within 14 days of receiving the request from any tenderer.

7. Corrupt and fraudulent practices

7.1 The procuring entity requires that the tenderer observes the highest standard of ethics during the procurement process and execution of the contract. A tenderer shall sign a declaration that he has not and will not be involved in corrupt and fraudulent practices.

7.2 The procuring entity will reject a tender if it determines that the tenderer recommended for award has engaged in corrupt and fraudulent practices in competing for the contract in question.

7.3 Further a tenderer who is found to have indulged in corrupt and fraudulent practices risks being debarred from participating in public procurement in Kenya.

Appendix to Instructions to Tenderers

Notes on the Appendix to the Instruction to Tenderers

1. The Appendix to instructions to tenderers is intended to assist the procuring entity in providing specific information in relation to the corresponding clause in the instructions to Tenderers and has to be prepared for each specific procurement.
2. The procuring entity should specify in the appendix information and requirements specific to the circumstances of the procuring entity, the goods to be procured and the tender evaluation criteria that will apply to the tenders.
3. In preparing the Appendix the following aspects should be taken into consideration;
 - (a) The information that specifies and complements provisions of Instruction to tenderers to be incorporated
 - (b) Amendments and/or supplements if any, to provisions of Section 2.0 as necessitated by the circumstances of the goods to be procured to be also incorporated
4. Section II should remain unchanged and can only be amended through the Appendix.
5. Clauses to be included in this part must be consistent with the public procurement law and the regulations.

Appendix to Instructions to Tenderers/General information

The following information regarding the particulars of the tender shall complement supplement or amend the provisions of the instructions to tenderers. Wherever there is a conflict between the provision of the instructions to tenderers and the provisions of the appendix, the provisions of the appendix herein shall prevail over those of the instructions to tenderers

INSTRUCTIONS TO TENDERERS REFERENCE	PARTICULARS OF APPENDIX TO INSTRUCTIONS TO TENDERS
	<i>The bidders shall submit their bid through ifmis supplier portal by the negotiations numbers attached to the tender document on or before Thursday, 5TH MARCH 2020 at 10.00 Am</i>
	<i>The bidder shall submit a minimum bid security of 2% OF TENDER SUM from a reputable bank or recognized insurance company</i>
	<i>Bidders who do not submit their bids through ifmis portal will be not be considered for evaluation of the bids.</i>

EVALUATION AND COMPARISON OF TENDERS

Evaluation and comparison of Tenders: the following evaluation criteria shall be applied not withstanding any other requirement in the tender documents.

a) Mandatory requirements(MR)

The following requirements must be met by the tenderer

PRELIMINARY EVALUATION CRITERIA

S/No	REQUIREMENTS	Score Mandatory (Yes/No)	B1	B2	B3	B4	B5	B6
1	Dully filled and stamped confidential business questionnaire	Mandatory (Yes/No)						
2	Form of tender duly filled, signed and stamped	Mandatory (Yes/No)						
3	The form of power of attorney shall be duly filled, signed and stamped	Mandatory (Yes/No)						
4	Bid Security (2% of tender sum from a reputable bank or insurance firm)	Mandatory (Yes/No)						
5	Certified Valid current year business permits.	Mandatory (Yes/No)						
6	Certified Valid current year tax compliance certificate.	Mandatory (Yes/No)						
7	Certified Certificate of incorporation.	Mandatory (Yes/No)						
8	Certified PIN/VAT certificate from KRA	Mandatory (Yes/No)						
9	Certified Certificate of Registration with NCA for water works NCA 8 and above	Mandatory (Yes/No)						

5.	Bidders shall attach audited financial reports for the last two years (2018,2017) certified	10 Marks								
6.	Duly filled, signed and stamped BQ attached to the company profile	25 Marks								
7	Attach proof of ownership/lease of equipment	5 Marks								
8	Attach bank statement for the last 6 months	5Marks								
	Total	70 Marks								

a) Technical evaluations scores

This section (technical evaluation) will be marked out of 70 and will determine the technical scorers (TS). Note: at this stage any firm that failed to score above 0r 49/70 shall NOT be evaluated financially.

SECTION III – CONDITIONS OF CONTRACT

1. Definitions

1.1 In this Contract, except where context otherwise requires, the following terms shall be interpreted as indicated;

“Bills of Quantities” means the priced and completed Bill of Quantities forming part of the tender[where applicable].

“Schedule of Rates” means the priced Schedule of Rates forming part of the tender [where applicable].

“The Completion Date” means the date of completion of the Works as certified by the Employer’s Representative.

“The Contract” means the agreement entered into by the Employer and the Contractor as recorded in the Agreement Form and signed by the parties.

“The Contractor” refers to the person or corporate body whose

tender to carry out the Works has been accepted by the Employer.

“The Contractor’s Tender” is the completed tendering document submitted by the Contractor to the Employer.

“The Contract Price” is the price stated in the Letter of Acceptance.

“Days” are calendar days; “Months” are calendar months.

“A Defect” is any part of the Works not completed in accordance with the Contract.

“The Defects Liability Certificate” is the certificate issued by Employer’s Representative upon correction of defects by the Contractor.

“The Defects Liability Period” is the period named in the Appendix to Conditions of Contract and calculated from the Completion Date.

“Drawings” include calculations and other information provided or approved by the Employer’s Representative for the execution of the Contract.

“Employer” Includes Central or Local Government Administration, Universities, Public Institutions and Corporations and is the party who employs the Contractor to carry out the Works.

“Equipment” is the Contractor’s machinery and vehicles brought temporarily to the Site for the execution of the Works.

“Site” means the place or places where the permanent Works are to be carried out including workshops where the same is being prepared.

“Materials” are all supplies, including consumables, used by the Contractor for incorporation in the Works.

“Employer’s Representative” is the person appointed by the Employer and notified to the Contractor for the purpose of supervision of the Works.

“Specification” means the Specification of the Works included in the Contract.

“Start Date” is the date when the Contractor shall commence execution of the Works.

“A Subcontractor” is a person or corporate body who has a Contract with the Contractor to carry out a part of the Work in the Contract, which includes Work on the Site.

“Temporary works” are works designed, constructed, installed, and removed by the Contractor which are needed for construction or installation of the Works.

“A Variation” is an instruction given by the Employer’s Representative which varies the Works.

“The Works” are what the Contract requires the Contractor to construct, install, and turnover to the Employer.

2. Contract Documents

- 2.1 The following documents shall constitute the Contract documents and shall be interpreted in the following order of priority;
- (1) Agreement,
 - (2) Letter of Acceptance,
 - (3) Contractor’s Tender,
 - (4) Conditions of Contract,
 - (5) Specifications,
 - (6) Drawings,
 - (7) Bills of Quantities or Schedule of Rates [whichever is applicable]

3. Employer’s Representative’s Decisions

- 3.1 Except where otherwise specifically stated, the Employer’s Representative will decide contractual matters between the Employer and the Contractor in the role representing the Employer.

4. Works, Language and Law of Contract

- 4.1 The Contractor shall construct and install the Works in accordance with the Contract documents. The Works may commence on the Start Date and shall be carried out in accordance with the Program submitted by the Contractor, as updated with the approval of the Employer’s Representative,

and complete them by the Intended Completion Date.

- 4.2 The ruling language of the Contract shall be English language and the law governing the Contract shall be the law of the Republic of Kenya.

5. Safety, Temporary works and Discoveries

- 5.1 The Contractor shall be responsible for design of temporary works and shall obtain approval of third parties to the design of the temporary works where required.

- 5.2 The Contractor shall be responsible for the safety of all activities on the Site.

- 5.3 Any thing of historical or other interest or significant value unexpectedly discovered on the Site shall be the property of the Employer. The Contractor shall notify the Employer's Representative of such discoveries and carry out the Employer's Representative's instructions for dealing with them.

6 Work Program and Sub-contracting

- 6.1 Within seven days after Site possession date, the Contractor shall submit to the Employer's Representative for approval a program showing the general methods, arrangements, order and timing for all the activities in the Works.

- 6.2 The Contractor may sub-contract the Works (but only to a maximum of 25 percent of the Contract Price) with the approval of the Employer's Representative. However, he shall not assign the Contract without the approval of the Employer in writing. Sub-contracting shall not alter the Contractor's obligations.

7 The site

- 7.1 The Employer shall give possession of all parts of the Site to the Contractor. The Contractor shall allow the Employer's Representative and any other person authorised by the Employer's Representative, access to the Site and to any place where work in connection with the Contract is being carried out or is intended to be carried out.

8 Instructions

- 8.1 The Contractor shall carry out all instructions of the Employer's Representative which are in accordance with the Contract.

9 Extension of Completion Date

- 9.1 The Employer's Representative shall extend the Completion Date if an occurrence arises which makes it impossible for completion to be achieved by the Intended Completion Date. The Employer's Representative shall decide whether and by how much to extend the Completion Date.

- 9.2 For the purposes of this clause, the following occurrences shall be valid for consideration;

Delay by:-

- (a) force majeure, or
- (b) reason of any exceptionally adverse weather conditions, or
- (c) reason of civil commotion, strike or lockout affecting any of the trades employed upon the Works or any of the trades engaged in the preparation, manufacture or transportation of any of the goods or materials required for the Works, or
- (d) reason of the Employer's Representative's instructions issued under these Conditions, or
- (e) reason of the contractor not having received in due time necessary instructions, drawings, details or levels from the Employer's Representative for which he specifically applied in writing on a date which having regard to the date for Completion stated in the appendix to these Conditions or to any extension of time then fixed under this clause was neither unreasonably distant from nor unreasonably close to the date on which it was necessary for him to receive the same, or
- (f) delay on the part of artists, tradesmen or others engaged by the Employer in executing work not forming part of this Contract, or
- (g) reason of delay by statutory or other services providers or similar bodies engaged directly by the Employer, or
- (h) reason of opening up for inspection of any Work covered

up or of the testing or any of the Work, materials or goods in accordance with these conditions unless the inspection or test showed that the Work, materials or goods were not in accordance with this Contract, or

- (i) reason of delay in appointing a replacement Employer's Representative, or
- (j) reason of delay caused by the late supply of goods or materials or in executing Work for which the Employer or his agents are contractually obliged to supply or to execute as the case may be, or
- (k) delay in receiving possession of or access to the Site.

10 Management Meetings

- 10.1 A Contract management meeting shall be held regularly and attended by the Employer's Representative and the Contractor. Its business shall be to review the plans for the remaining Work. The Employer's Representative shall record the business of management meetings and provide copies of the record to those attending the meeting and the Employer. The responsibility of the parties for actions to be taken shall be decided by the Employer's Representative either at the management meeting or after the management meeting and stated in writing to all who attend the meeting.
- 10.2 Communication between parties shall be effective only when in writing.

11 Defects

- 11.1 The Employer's Representative shall inspect the Contractor's work and notify the Contractor of any defects that are found. Such inspection shall not affect the Contractor's responsibilities. The Employer's Representative may instruct the Contractor to search for a defect and to uncover and test any Work that the Employer's Representative considers may have a defect. Should the defect be found, the cost of uncovering and making good shall be borne by the Contractor. However if there is no defect found, the cost of uncovering and making good shall be treated as a variation and added to the Contract Price.
- 11.2 The Employer's Representative shall give notice to the

Contractor of any defects before the end of the Defects Liability Period, which begins at Completion, and is defined in the Appendix to Conditions of Contract.

- 11.3 Every time notice of a defect is given, the Contractor shall correct the notified defect within the length of time specified by the Employer's Representative's notice. If the Contractor has not corrected a defect within the time specified in the Employer's Representative's notice, the Employer's Representative will assess the cost of having the defect corrected by other parties and such cost shall be treated as a variation and be deducted from the Contract Price.

12 Bills of Quantities/Schedule of Rates

- 12.1 The Bills of Quantities/Schedule of Rates shall contain items for the construction, installation, testing and commissioning of the Work to be done by the Contractor. The Contractor will be paid for the quantity of the Work done at the rates in the Bills of Quantities/Schedule of Rates for each item. Items against which no rate is entered by the Tenderer will not be paid for when executed and shall be deemed covered by the rates for other items in the Bills of Quantities/Schedule of Rates.
- 12.2 Where Bills of Quantities do not form part of the Contract, the Contract Price shall be a lump sum (which shall be deemed to have been based on the rates in the Schedule of Rates forming part of the tender) and shall be subject to re-measurement after each stage.

13 Variations

- 13.1 The Contractor shall provide the Employer's Representative with a quotation for carrying out the variations when requested to do so. The Employer's Representative shall assess the quotation and shall obtain the necessary authority from the Employer before the variation is ordered.
- 13.2 If the Work in the variation corresponds with an item description in the Bill of Quantities/Schedule of Rates, the rate in the Bill of Quantities/Schedule of Rates shall be used to calculate the value of the variation. If the nature of the Work in the variation does not correspond with items in the Bill of Quantities/Schedule of Rates, the quotation by the Contractor shall be in the form of new rates for the relevant items of Work.

13.3 If the Contractor's quotation is unreasonable, the Employer's Representative may order the variation and make a change to the Contract Price, which shall be based on the Employer's Representative's own forecast of the effects of the variation on the Contractor's costs.

14 Payment Certificates and Final Account

14.1 The Contractor shall be paid after each of the following stages of Work listed herebelow (subject to re-measurement by the Employer's Representative of the Work done in each stage before payment is made). In case of lump-sum Contracts, the valuation for each stage shall be based on the quantities so obtained in the re-measurement and the rates in the Schedule of Rates.

- (i) Advance payment
(*percent of Contract Price,*
[after Contract *to be inserted by the*
execution] *Employer*).
- (ii) First stage (*define stage*)
- (iii) Second stage (*define stage*)
- (iv) Third stage (*define stage*)
- (v) After defects liability period .

14.2 Upon deciding that Works included in a particular stage are complete, the Contractor shall submit to the Employer's Representative his application for payment. The Employer's Representative shall check, adjust if necessary and certify the amount to be paid to the Contractor within 21 days of receipt of the Contractor's application .The Employer shall pay the Contractor the amounts so certified within 30 days of the date of issue of each Interim Certificate.

14.3 The Contractor shall supply the Employer's Representative with a detailed final account of the total amount that the Contractor considers payable under the Contract before the end of the Defects Liability Period. The Employer's Representative shall issue a Defect Liability Certificate and certify any final payment that is due to the Contractor within 30 days of receiving the Contractor's account if it is correct and complete. If it is not, the

Employer's Representative shall issue within 21 days a schedule that states the scope of the corrections or additions that are necessary. If the final account is still unsatisfactory after it has been resubmitted, the Employer's Representative shall decide on the amount payable to the Contractor and issue a Final Payment Certificate. The Employer shall pay the Contractor the amount so certified within 60 days of the issue of the Final Payment Certificate.

14.4 If the period laid down for payment to the Contractor upon each of the Employer's Representative's Certificate by the Employer has been exceeded, the Contractor shall be entitled to claim simple interest calculated pro-rata on the basis of the number of days delayed at the

Central Bank of Kenya's average base lending rate prevailing on the first day the payment becomes overdue. The Contractor will be required to notify the Employer within 15 days of receipt of delayed payments of his intentions to claim interest.

15. Insurance

15.1 The Contractor shall be responsible for and shall take out appropriate cover against, among other risks, personal injury; loss of or damage to the Works, materials and plant; and loss of or damage to property.

16. Liquidated Damages

16.1 The Contractor shall pay liquidated damages to the Employer at the rate 0.001 per cent of the Contract price per day for each day that the actual Completion Date is later than the Intended Completion Date except in the case of any of the occurrences listed under clause 9.2. The Employer may deduct liquidated damages from payments due to the Contractor. Payment of liquidated damages shall not affect the Contractor's liabilities.

17. Completion and Taking Over

17.1 Upon deciding that the Work is complete the Contractor shall request the Employer's Representative to issue a Certificate of Completion of the Works, upon deciding that the Work is completed.

The Employer shall take over the Site and the Works within seven days of the Employer's Representative issuing a

Certificate of Completion.

18. Termination

18.1 The Employer or the Contractor may terminate the Contract if the other party causes a fundamental breach of the Contract. These fundamental breaches of Contract shall include, but shall not be limited to, the following;

- (a) the Contractor stops Work for 30 days continuously without reasonable cause or authority from the Employer's Representative;
- (b) the Contractor is declared bankrupt or goes into liquidation other than for a reconstruction or amalgamation;
- (c) a payment certified by the Employer's Representative is not paid by the Employer to the Contractor within 30 days after the expiry of the payment periods stated in sub clauses 14.2 and 14.3 hereinabove.
- (d) the Employer's Representative gives notice that failure to correct a particular defect is a fundamental breach of Contract and the Contractor fails to correct it within a reasonable period of time.

18.2 If the Contract is terminated, the Contractor shall stop Work immediately, and leave the Site as soon as reasonably possible. The Employer's Representative shall immediately thereafter arrange for a meeting for the purpose of taking record of the Works executed and materials, goods, equipment and temporary buildings on Site.

19. Payment Upon Termination

19.1 The Employer may employ and pay other persons to carry out and complete the Works and to rectify any defects and may enter upon the Works and use all materials on Site, plant, equipment and temporary works.

19.2 The Contractor shall, during the execution or after the completion of the Works under this clause, remove from the Site as and when required within such reasonable time as the Employer's Representative may in writing specify, any temporary buildings, plant, machinery,

appliances, goods or materials belonging to him, and in default thereof, the Employer may (without being responsible for any loss or damage) remove and sell any such property of the Contractor, holding the proceeds less all costs incurred to the credit of the Contractor.

19.3 Until after completion of the Works under this clause, the Employer shall not be bound by any other provision of this Contract to make any payment to the Contractor, but upon such completion as aforesaid and the verification within a reasonable time of the accounts therefor the Employer's Representative shall certify the amount of expenses properly incurred by the Employer and, if such amount added to the money paid to the Contractor before such determination exceeds the total amount which would have been payable on due completion in accordance with this Contract, the difference shall be a debt payable to the Employer by the Contractor; and if the said amount added to the said money be less than the said total amount, the difference shall be a debt payable by the Employer to the Contractor.

20. Corrupt Gifts and Payments of Commission

20.1 The Contractor shall not;

- (a) Offer or give or agree to give to any person in the service of the Employer any gifts or consideration of any kind as an inducement or reward for doing or forbearing to do or for having done or forborne to do any act in relation to the obtaining or execution of this or any other contract with the Employer or for showing or forbearing to show favour or disfavour to any person in relation to this or any other contract with the Employer.
- (b) Any breach of this Condition by the Contractor or by anyone employed by him or acting on his behalf (whether with or without the knowledge of the Contractor) shall be an offence under the Laws of Kenya.

21. Settlement of Disputes

21.1 Any dispute arising out of the Contract which cannot be amicably settled between the parties shall be referred by either party to the arbitration and final decision of a person to be agreed between the parties. Failing agreement to concur in the appointment of an Arbitrator, the

Arbitrator shall be appointed by the chairman of the Chartered Institute of Arbitrators, Kenya branch, on the request of the applying party.

SECTION IV – APPENDIX TO CONDITIONS OF CONTRACT

THE EMPLOYER IS

Name: **GOVERNOR - MANDERA COUNTY GOVERNMENT**
Address: **P.O Box 13, MANDERA**

Name of Authorized Representative: **County Executive Committee Member – WATER, ENERGY & NATURAL RESOURCES.**

Cell phone:
E-mail:/Fax:

Name of Alternative Representative: **Chief Officer - Water.**
Cell phone:
E-mail:/Fax:

The Project Manager is: **County Director – Water, Mandera County.**
Address: **P.O. BOX 49, MANDERA**
Cell phone:

1.2 The name (and identification number) of the Contract is: PROPOSED DESILTING AND EXPANSION OF 20,000 CUBIC METRE EARTH PAN AT SUKELA LOQO MANDERA WEST SUB-COUNTY.

1.3 The works consist of: PROPOSED DESILTING AND EXPANSION OF 20,000 CUBIC METRE EARTH PAN AT SUKELA LOQO MANDERA WEST SUB-COUNTY.

The Start Date shall be **AGREED WITH THE PROJECT MANAGER**

The Intended Completion Date for the whole of the Works shall be **fifty two weeks (52)** from **the commencement date as agreed with the Project Manager.**

The following documents also form part of the Contract:
AS LISTED IN CLAUSE 2.3 OF CONDITIONS OF CONTRACT

The Contractor shall submit a revised program for the Works within **fourteen days(14)** days of delivery of the Letter of Acceptance.

The Site Possession Date shall be **AGREED WITH THE PROJECT MANAGER**
The Defects Liability period is **180** days

The minimum insurance covers shall be; **“ALL RISKS INSURANCE”**

The following events shall also be Compensation Events:

- 1. NONE (ONLY AS LISTED IN CLAUSE 24 OF THE CONDITIONS OF CONTRACT**
- 2. _____
- 3. _____

4. _____

The period between Program updates is **15** days.

The amount to be withheld for late submission of an updated Program is **FULL CERTIFICATE**

The proportion of payments retained is **10%** percent.

The Price Adjustment Clause **SHALL NOT** apply

The liquidated damages for the whole of the Works is Kshs.**1,000.00** (per week)

The Performance Security shall be for the following minimum amounts equivalent as a percentage of the Contract Price **10 percent (%)**

The Completion Period for the Works is **fifty two weeks (52)**

The rate of exchange for calculation of foreign currency payments is **not applicable**

The schedule of basic rates used in pricing by the Contractor is as attached [*Contractor to attach*].

Advance Payment **SHALL NOT be** granted.

The Bidder should submit **ONLY ONE (1 NO.) ORIGINAL AND A COPY** of the Bills of Quantities as indicated in Clause 4.1 of the Instruction to Tenderers.

This Tender must be accompanied by a Bid Bond or else the tender shall be disqualified.

SECTION V- STANDARD FORM

- (i) Form of Invitation for Tenders
- (ii) Form of Tender
- (iii) Letter of Acceptance
- (iv) Form of Agreement
- (v) Form of Tender Security
- (vi) Performance Bank Guarantee
- (vii) Bank Guarantee for Advance Payment
- (viii) Qualification Information
- (ix) Tender Questionnaire
- (xi) Confidential Business Questionnaire
- (x) Request for Review Form

FORM OF TENDER

TO: MANDERA COUNTY GOVERNMENT

_____ [Date]

1.4 **REF:** TENDER FOR PROPOSED DESILTING AND EXPANSION OF 20,000 CUBIC METRE EARTH PAN AT SUKELA LOQO MANDERA WEST SUB-COUNTY

Dear Sir,

1. In accordance with the Conditions of Contract, Specifications, Drawings and Bills of Quantities for the execution of the above named Works, we, the undersigned offer to construct, install and complete such Works and Remedy any defects therein for the sum of

Kshs. _____ [Amount in figures] Kenya

Shillings _____ [Amount in words]

2. We undertake, if our tender is accepted, to commence the Works as soon as is reasonably possible after the receipt of the Project Manager's notice to commence, and to complete the whole of the Works comprised in the Contract within the time stated in the Appendix to Conditions of Contract.
3. We agree to abide by this tender for 120 days from the date of submission, and it shall remain binding upon us and may be accepted at any time before that date.
4. Unless and until a formal Agreement is prepared and executed this tender together with your written acceptance thereof, shall constitute a binding Contract between us.
5. We understand that you are not bound to accept the lowest or any tender you may receive.

Dated this _____ day of _____ 20_____

Signature _____ in the capacity of _____

duly authorized to sign tenders for and on behalf of
_____ [Name of Employer]
of _____ [Address of Employer]

Witness; Name _____

Address _____

Signature _____

Date _____

LETTER OF ACCEPTANCE
[letterhead paper of the Employer]

_____ [date]

To: _____
[name of the Contractor]

[address of the Contractor]

Dear Sir,

This is to notify you that your Tender dated _____
for the execution of _____
[name of the Contract and identification number, as given in the Tender documents]
for the Contract Price of Kshs. _____ *[amount in*
figures] Kenya Shillings _____ *(amount in words)*] in
accordance with the Instructions to Tenderers is hereby accepted.

You are hereby instructed to proceed with the execution of the said Works in
accordance with the Contract documents.

Authorized Signature

Name and Title of Signatory

Attachment : Agreement

FORM OF AGREEMENT

THIS AGREEMENT, made the _____ day of _____ 20 _____ between **MANDERA COUNTY GOVERNMENT** of [or whose registered office is situated at] **P.O BOX 13, MANDERA, KENYA** (hereinafter called “the Employer”) of the one part AND

_____ of [or whose registered office is situated at] _____ (hereinafter called “the Contractor”) of the other part.

WHEREAS THE Employer is desirous that the Contractor executes PROPOSED DESILTING AND EXPANSION OF 20,000 CUBIC METRE EARTH PAN AT SUKELA LOQO MANDERA WEST SUB-COUNTY (RE-ADVERTISEMENT) MCG/OT/2019-2020 (*name and identification number of Contract*) (hereinafter called “the Works”) located at **Mandera County** [Place/location of the Works] and the Employer has accepted the tender submitted by the Contractor for the execution and completion of such Works and the remedying of any defects therein for the Contract Price of Kshs _____ [Amount in figures], Kenya Shillings _____ [Amount in words].

NOW THIS AGREEMENT WITNESSETH as follows:

1. In this Agreement, words and expressions shall have the same meanings as are respectively assigned to them in the Conditions of Contract hereinafter referred to.
2. The following documents shall be deemed to form and shall be read and construed as part of this Agreement i.e.
 - (i) Letter of Acceptance
 - (ii) Form of Tender
 - (iii) Conditions of Contract Part I
 - (iv) Conditions of Contract Part II and Appendix to Conditions of Contract

- (v) Specifications
- (vi) Drawings
- (vii) Priced Bills of Quantities

3. In consideration of the payments to be made by the Employer to the Contractor as hereinafter mentioned, the Contractor hereby covenants with the Employer to execute and complete the Works and remedy any defects therein in conformity in all respects with the provisions of the Contract.

1. The Employer hereby covenants to pay the Contractor in consideration of the execution and completion of the Works and the remedying of defects therein, the Contract Price or such other sum as may become payable under the provisions of the Contract at the times and in the manner prescribed by the Contract.

IN WITNESS whereof the parties thereto have caused this Agreement to be executed the day and year first before written.

The common Seal of _____

Was hereunto affixed in the presence of _____

Signed Sealed, and Delivered by the said _____

Binding Signature of Employer _____

Binding Signature of Contractor _____

In the presence of (i) Name _____

Address _____

Signature _____

[ii] Name _____

Address _____

Signature _____

PERFORMANCE BANK GUARANTEE

To: _____(Name of Employer) _____(Date)
_____(Address of Employer)

Dear Sir,

WHEREAS _____(hereinafter called "the Contractor") has undertaken, in pursuance of Contract No. _____ dated _____ to execute _____ (hereinafter called "the Works");

AND WHEREAS it has been stipulated by you in the said Contract that the Contractor shall furnish you with a Bank Guarantee by a recognised bank for the sum specified therein as security for compliance with his obligations in accordance with the Contract;

AND WHEREAS we have agreed to give the Contractor such a Bank Guarantee:

NOW THEREFORE we hereby affirm that we are the Guarantor and responsible to you, on behalf of the Contractor, up to a total of Kshs. _____
(amount of Guarantee in figures) Kenya Shillings _____ (amount of Guarantee in words), and we undertake to pay you, upon your first written demand and without cavil or argument, any sum or sums within the limits of Kenya Shillings _____ (amount of Guarantee in words) as aforesaid without your needing to prove or to show grounds or reasons for your demand for the sum specified therein.

We hereby waive the necessity of your demanding the said debt from the Contractor before presenting us with the demand.

We further agree that no change, addition or other modification of the terms of the Contract or of the Works to be performed thereunder or of any of the Contract documents which may be made between you and the Contractor shall in any way release us from any liability under this Guarantee, and we hereby waive notice of any change, addition, or modification.

This guarantee shall be valid until the date of issue of the Certificate of Completion.

SIGNATURE AND SEAL OF THE GUARANTOR _____

Name of Bank _____

Address _____

Date _____

BANK GUARANTEE FOR ADVANCE PAYMENT

To: _____ [name of Employer] _____ (Date)
_____ [address of Employer]

Gentlemen,

Ref: _____ [name of Contract]

In accordance with the provisions of the Conditions of Contract of the above-mentioned Contract, We, _____ [name and Address of Contractor] (hereinafter called "the Contractor") shall deposit with _____ [name of Employer] a bank guarantee to guarantee his proper and faithful performance under the said Contract in an amount of Kshs. _____ [amount of Guarantee in figures] Kenya Shillings _____ [amount of Guarantee in words].

We, _____ [bank or financial institution], as instructed by the Contractor, agree unconditionally and irrevocably to guarantee as primary obligator and not as Surety merely, the payment to _____ [name of Employer] on his first demand without whatsoever right of objection on our part and without his first claim to the Contractor, in the amount not exceeding Kshs _____ [amount of Guarantee in figures] Kenya Shillings _____ [amount of Guarantee in words], such amount to be reduced periodically by the amounts recovered by you from the proceeds of the Contract.

We further agree that no change or addition to or other modification of the terms of the Contract or of the Works to be performed thereunder or of any of the Contract documents which may be made between _____ [name of Employer] and the Contractor, shall in any way release us from any liability under this guarantee, and we hereby waive notice of any such change, addition or modification.

No drawing may be made by you under this guarantee until we have received notice in writing from you that an advance payment of the amount listed above has been paid to the Contractor pursuant to the Contract.

This guarantee shall remain valid and in full effect from the date of the advance payment under the Contract until _____ (name of Employer) receives full payment of the same amount from the Contract.

Yours faithfully,

Signature and Seal _____

Name of the Bank or financial institution _____

Address _____

Date _____

Witness: Name: _____

Address: _____

Signature: _____

Date: _____

CONFIDENTIAL BUSINESS QUESTIONNAIRE

You are requested to give the particulars indicated in Part 1 and either Part 2 (a), 2 (b) or 2 (c) and 2 (d) whichever applies to your type of business.

You are advised that it is a serious offence to give false information on this Form.

Part 1 – General

Business Name

Location of business premises; Country/Town.....

Plot No..... Street/Road

Postal Address..... Tel No.....

Nature of Business.....

Current Trade Licence No..... Expiring date.....

Maximum value of business which you can handle at any time: K. pound.....

Name of your bankers.....

Branch.....

Part 2 (a) – Sole Proprietor

Your name in full..... Age.....

Nationality..... Country of Origin.....

*Citizenship details

Part 2 (b) – Partnership

Give details of partners as follows:

	<i>Name in full</i>	<i>Nationality</i>	<i>Citizenship Details</i>	<i>Shares</i>
1.
2.
3.

Part 2(c) – Registered Company:

Private or public.....

State the nominal and issued capital of the Company-

Nominal Kshs.....

Issued Kshs.....

Give details of all directors as follows:

Name in full . Nationality. Citizenship Details*. Shares.

1.
.....

2.
.....

3.
.....

4.
.....

Part 2(d) – Interest in the Firm:

Is there any person / persons in(Name of Employer) who has interest in this firm? Yes/No.....(Delete as necessary)

I certify that the information given above is correct.

.....
(Title) (Signature) (Date)

- Attach proof of citizenship

LETTER OF NOTIFICATION OF AWARD

Address of Procuring Entity

To: _____

RE: Tender No. _____

Tender Name _____

This is to notify that the contract/s stated below under the above mentioned tender have been awarded to you.

1. Please acknowledge receipt of this letter of notification signifying your acceptance.
2. The contract/contracts shall be signed by the parties within 30 days of the date of this letter but not earlier than 14 days from the date of the letter.
3. You may contact the officer(s) whose particulars appear below on the subject matter of this letter of notification of award.

(FULL PARTICULARS) _____

SIGNED FOR ACCOUNTING OFFICER

FORM RB 1

REPUBLIC OF KENYA
PUBLIC PROCUREMENT ADMINISTRATIVE REVIEW BOARD

APPLICATION NO.....OF.....20.....

BETWEEN

.....APPLICANT

AND

.....RESPONDENT (*Procuring Entity*)

Request for review of the decision of the..... (*Name of the Procuring Entity*) of
.....dated the...day of20.....in the matter of Tender No.....of
.....20...

REQUEST FOR REVIEW

I/We.....,the above named Applicant(s), of address: Physical
address.....Fax No.....Tel. No.....Email, hereby request the Public
Procurement Administrative Review Board to review the whole/part of the above
mentioned decision on the following grounds , namely:-1.

- 2.
- etc.

By this memorandum, the Applicant requests the Board for an order/orders that: -

- 1.
- 2.
- etc

SIGNED(Applicant)

Dated on.....day of/...20...

FOR OFFICIAL USE ONLY

Lodged with the Secretary Public Procurement Administrative Review Board on

day of20.....

SIGNED

Board Secretary

FORM OF POWER OF ATTORNEY

(All bidders shall complete this form otherwise, their bids shall be considered non-responsive)

We _____ (Name of Bidder)

having our offices located in _____ (Name of Town and Building)
duly authorise

_____ (Name of person appointed to act for and on
behalf of the bidder) to act for and on our behalf on all matters pertaining to the execution of
works as stipulated und

Duly signed and delivered:

Name of appointed attorney: _____

Signature of appointed attorney: _____

Witnessed by:

1. Name of First Company Director: _____

Signature: _____

2. Name of Second Company Director: _____

Signature: _____

Company Seal:

SECTION VI – SPECIFICATIONS, DRAWINGS & BILLS OF QUANTITIES

SPECIFICATIONS

Notes for preparing Specifications

- 1.0 Specifications must be drafted to present a clear and precise statement of the required standards of materials, and workmanship for tenderers to respond realistically and competitively to the requirements of the Employer and ensure responsiveness of tenders. The Specifications should require that all materials, plant, and other supplies to be permanently incorporated in the Works be new, unused, of the most recent or current models, and incorporating all recent improvements in design and materials unless provided otherwise in the Contract. Where the Contractor is responsible for the design of any part of the permanent Works, the extent of his obligations must be stated.
- 2.0 Specifications from previous similar projects are useful and may not be necessary to re-write specifications for every Works Contract.
- 3.0 There are considerable advantages in standardizing **General Specifications** for repetitive Works in recognized public sectors, such as highways, urban housing, irrigation and water supply. The General Specifications should cover all classes of workmanship, materials and equipment commonly involved in constructions, although not necessarily to be used in a particular works contract. Deletions or addenda should then adapt the General Specifications to the particular Works.
- 4.0 Care must be taken in drafting Specifications to ensure they are not restrictive. In the Specifications of standards for materials, plant and workmanship, existing Kenya Standards should be used as much as possible, otherwise recognized international standards may also be used.
- 5.0 The Employer should decide whether technical solutions to specified parts of the Works are to be permitted. Alternatives are appropriate in cases where obvious (and potentially less costly) alternatives are possible to the technical solutions indicated in tender documents for certain elements of the Works, taking into consideration the comparative specialized advantage of potential tenderers.

The Employer should provide a description of the selected parts of the Works with appropriate reference to Drawings, Specifications, Bills of Quantities, and Design or Performance criteria, stating that the alternative solutions shall be at least structurally and functionally equivalent to the basic design parameters and Specifications.

Such alternative solutions shall be accompanied by all information necessary for a complete evaluation by the Employer, including drawings, design calculations, technical specifications, breakdown of prices, proposed construction methodology, and other relevant details. Technical alternatives permitted in this manner shall be considered by the Employer each on its own merits and independently of whether the tenderer has priced the item as described in the Employer's design included with the tender documents.

BILL OF QUANTITIES

BILL OF QUANTITIES FOR DESILTING AND EXPANSION OF 20,000M³ EARTH PAN AT SUKELA LOQO MANDERA WEST SUB-COUNTY

Item No	DESCRIPTION	UNIT	QTY	RATE	AMOUNT
	Preliminaries and General Items				
01	Allow provisional sum for environmental Impact Assessment (EIA)	ITEM	L/S	40,000	40,000
02	Allow provisional sum for WRMA levies	item	L/S	30,000	30,000
03	Allow provisional sum for project supervision & administration	ITEM	L/S	500,000	500,000
04	Allow provisional sum for erection of sign board & maintenance over the contract period.	ITEM	L/S		
05	Allow provisional sum for setting out the Works	item	L/S		
06	Allow provisional sum for keeping site free from running water.	item	l/s		
07	Allow a provisional sum for temporary site office, stores, accommodation, sanitation, clean water, First Aid Kit & security	item	l/s		
08	Allow a provisional sum for mobilization of Plants, Equipment, Personnel and materials to site & demobilization after completion of the works.	KM	250		
09	The Contractor is to describe hereunder in detail and prices of other works, obligations and things which may be referred to in the conditions of contract & specifications or which may be considered have been omitted from the BQs that he may desire to enter a separate charge				
I					
II					
	SUB-TOTAL FOR BILL NO 1			KSHS	
	BILL NO. 2 : EARTHWORKS & EXCAVATIONS				
10	Carry out light bush clearing within the earth dam site and along the 200m long stretch around the pan site	SM	25,000		

11	Excavate oversight to remove vegetation soil and scrub clean to minimum depth of 150mm and stack for re-use to cover pan embankment	SM	25,000		
12	Excavate including ripping of the pan storage area to measure 100mx60m to a depth NOT Exceeding 1.5m should have slope of 1:3	CM	10,000		
13	Excavate including ripping of the pan storage area to measure 100mx60m to a depth from 1.5m to 3.0m and should have slope of 1:3	CM	10,000		
14	Embankment Construction Place earth along the embankment trench to construct a 3m wide well compacted embankment earth wall as per the instructions of the works supervisor/ Engineer	CM	15,000		
15	Dispose the extra excavated material and deposit away as directed by the Engineer by means dumpers.	CM	5,000		
SILT TRAP, INLET & SPILLWAY CONSTRUCTION,					
16	Excavate for silt trap construction measuring 30mx20mx2.0m deep having side slopes of 1:3	CM	1,200		
17	Excavate for intake channel construction measuring 5m wide, 25m long and having a maximum depth of 700mm	CM	60		
18	Excavate for spillway channel construction measuring 4.5m wide, 100m long and having a maximum depth of 500mm.	CM	330		
19	Excavate for inlet channel construction measuring 5m wide, 1.0km long and having a maximum depth of 1.0m	CM	5,000		
SUB-TOTAL FOR BILL NO. 2					KSHS
BILL NO 3 AUXILLARY WORKS					
20	FENCING Excavate pits for angle line fencing poles 300x300mm by 450mm deep 2.4m apart	NO	283		
21	Supply and erect heavy duty angle line steel sections measuring at least	NO	283		

	40mmx40mmx4mm thick and 3,000mm long as instructed on site				
22	Cover pits with mass concrete 1:2:4 to firmly Erect angle line posts in place	CM	15		
23	Provide Medium Gauge Chain-Link Fencing Wire to secure the Water Dam Reservoir	SM	1,470		
24	Supply and fix 8 strands of gauge 16 barbed wire at a uniform spacing of 300mm between the strands	LM	5880		
25	Fabricate and install a standard steel framed mesh fabric 125 Gate with lockable pedestrian door	NO	1		
	Inlet and spillway concrete protection				
26	Undertake construction of 25m long by 5m wide reinforced concrete intake channel while providing protection against erosion using riprap and gabions	CM	18		
27	Allow for the supply, preparation and placement of steel Reinforcement				
(i)	Y10 reinforcement bars	lengths	107		
(ii)	BRC mesh fabric No 125	SM	120		
(iii)	Filled , placed and properly anchored Gabion wires	NO	20		
28	Provision of timber formwork on sides of RC spillway protection	SM	15		
29	Undertake construction of 24m long by 4.5m wide Reinforced Concrete spillway to protect against erosion as directed by the Engineer while raising spillway bed by 400mm and providing for construction of concrete walling on spillway sides and stone riprap protection along contact areas with existing earth embankment	ITEM	L/S		
	SUB-TOTAL FOR BILL NO. 3			KSHS	
	GRAND TOTAL FOR EARTH PAN CONSTRUCTION			KSHS	

GRAND SUMMARY

S/NO	DESCRIPTION	AMOUNT(KSHS)
------	-------------	--------------

1.	Preliminaries and general items	
2.	Earthworks excavations	
3.	Auxillary Works	
4.	Add 5% Contingencies	
	GRAND TOTAL FOR ALL WORKS	KSHS

Kenya Shillings.....

.....

Contractor:

VAT Registration No:

Pin No:

Address:

Signature: Date:

Witness:

Address:

Signature: Date:

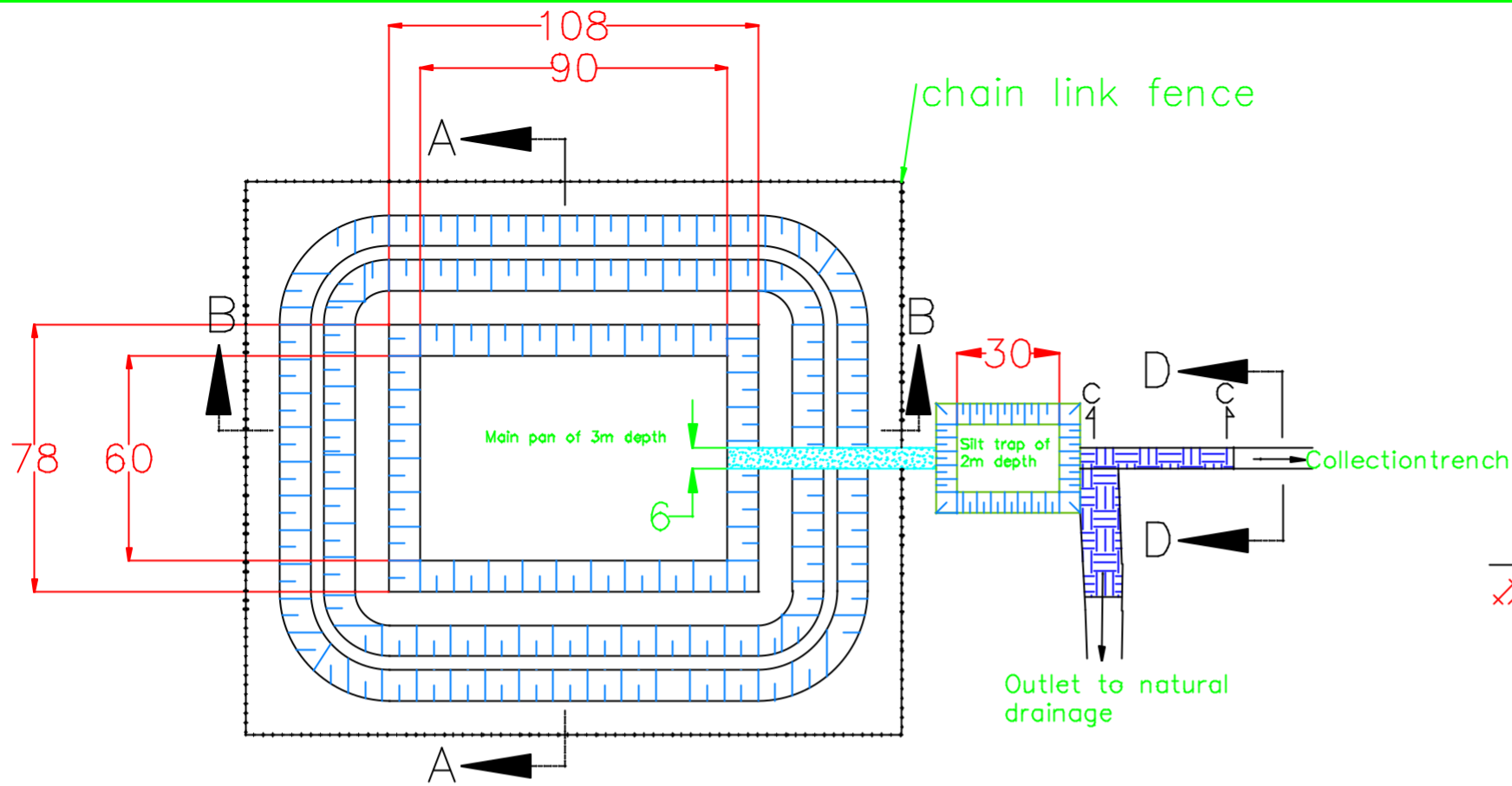

NOTE;
The exact location of the intake
to be decided for each site independtly.

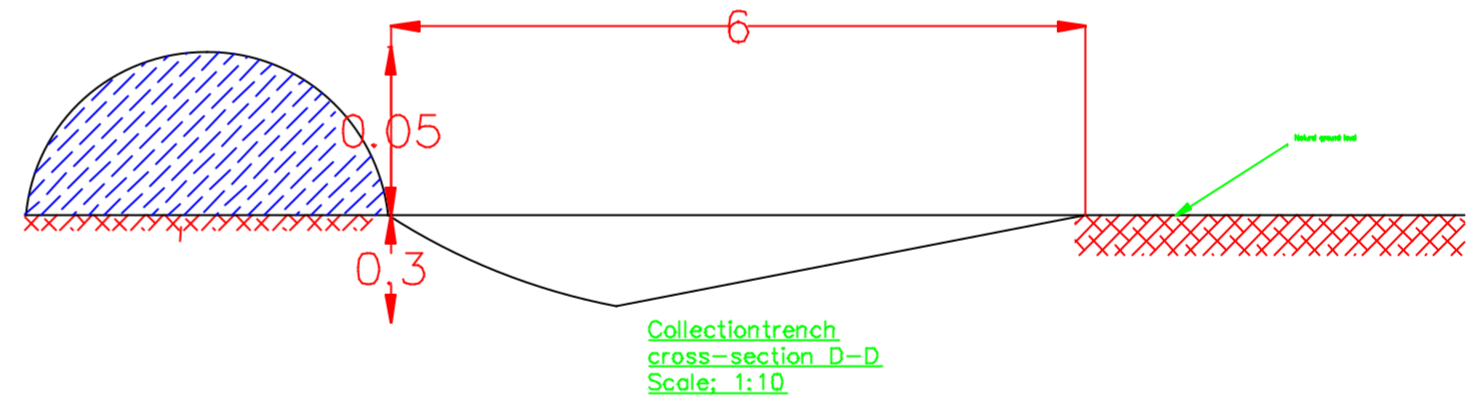
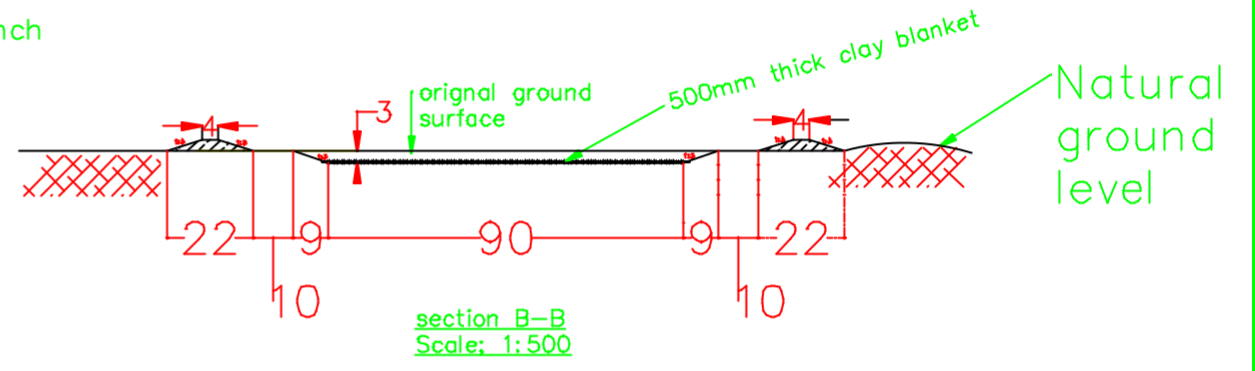
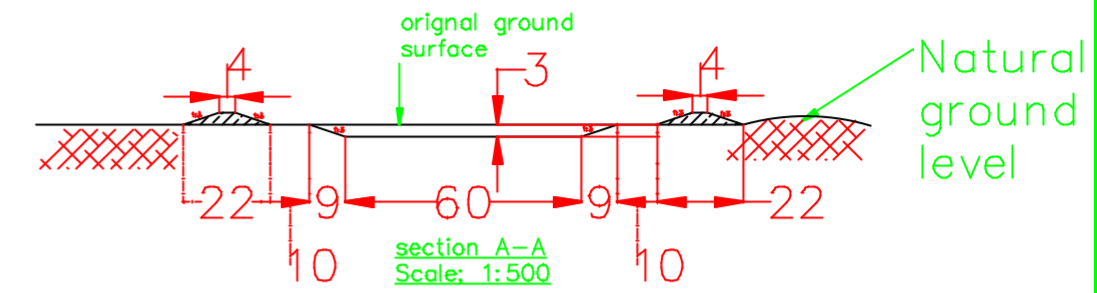
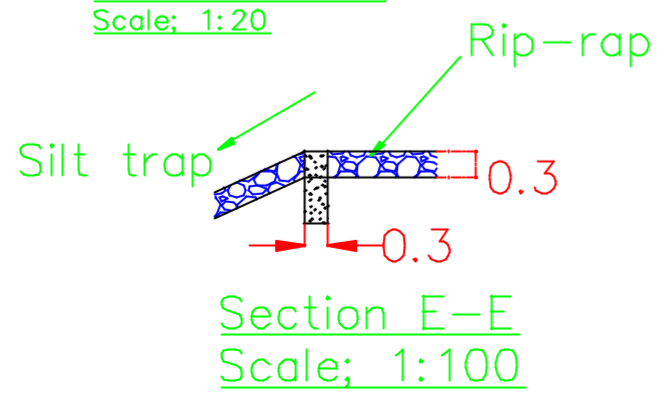
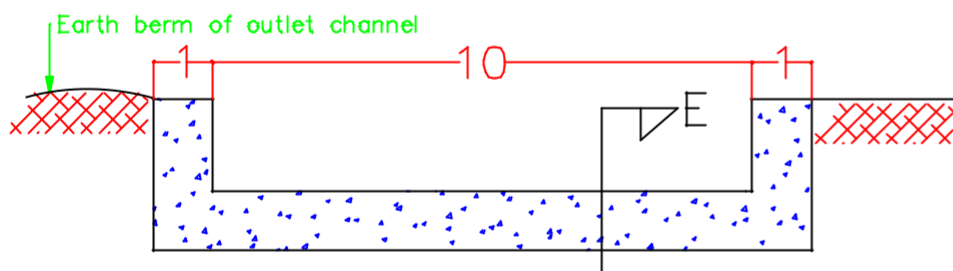

DEPARTMENT OF WATER SERVICES MANDERA COUNTY GOVERNMENT					
PROPOSED CONSTRUCTION OF 20,000M3 SUKELA LOQO WATER PAN					
DRAWN BY	YUSSUF	DEC 2019	SHEET NO. 1 OUT OF 1		
TRACED BY	IRSHAD	DEC 2019	SCALE	AS SHOWN IN DRWNGS	
CHECKED BY	Eng AHMED	DEC 2019	DRAWING NO.	MCG	
APPROVED BY	Eng. AHMED	DEC 2019			